

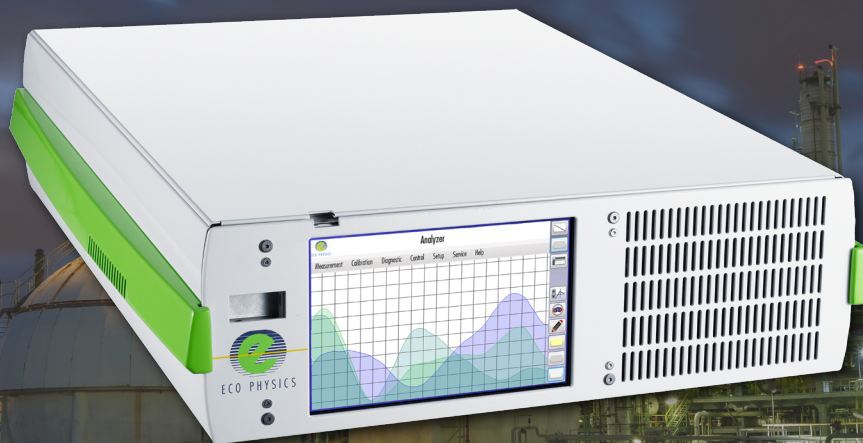

ECO PHYSICS nCLD 855 Y

APPLICATION EXAMPLES

- Gas manufacturers
- Manufacturers of gas turbines
- Certification and calibration
- DeNOx Plants
- Refining of fuels and lubricants
- Tobacco industry
- Research and development



The nCLD 855 Y analyzer is the next generation in two-channel high precision nitrogen oxide measurement. Unique in speed and reliability, the nCLD 855 Y is modular designed and capable of simultaneously measuring NO, NO₂ and NO_x. The analyzer's expandable capabilities allow assessment of hot and humid gas sources without additional cooler. The new and intuitive graphical user interface "GUI" also individually displays and connects to other instruments' data.

Measurement of:

- NO
- NO₂
- NO_x

nCLD - A New Generation

The nCLD 855 Y includes everything for measurement of NO, NO₂ and NO_x. The fully revised detector-block, the enhanced gas flow paths and the improved pressure as well as temperature independence of the nCLD 800 Series instruments allow for even lower detection limits. Overall stability and reliability are lifted to a new level. The optional electro-mechanical bypass system balances out even fastest pressure variations occurring in the sample flow. Furthermore, the analyzer is adaptable to numerous non-standardized applications. The calibration of the unit runs quickly and automatically, with all necessary data available anywhere and at any time.

User Friendliness with "GUI"

The new touch sensitive graphical user interface "GUI" enables the user to individually adjust the instrument operation and data management according to his/her needs and applications. The bright 8" monitor gives a clear overview and allows numerical and graphical display of values. Multiple digital in- and outputs guarantee a maximal connectivity for your remote operation, control and maintenance of the nCLD 855 Y, ensuring unsurpassed precision and reliability.

Compact, Modular and Intelligent!

The nCLD 855 Y is manufactured in a new compact and modular layout, in which each essential component of the chemiluminescence analyzer hosts its own CPU and interacts with other CPUs by BUS-communication. This assembly increases accessibility and serviceability by reducing wiring and piping. The measurement principle will conform to the standard method for NO_x-detection in ambient air (EN 14211).

- Rapid system integration and rack mounting
- Compact and modular design
- Virtually maintenance free even in continuous operation
- Four freely selectable measuring ranges

Graphical user interface "GUI" for individual analyzer operation and data management

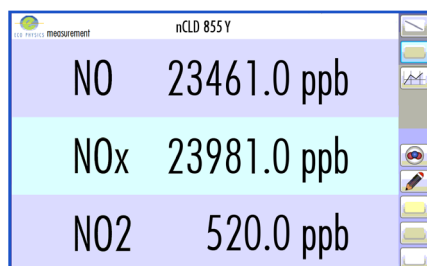

Measurably better

SPECIFICATIONS

nCLD 855 Y

Measuring ranges	four freely selectable ranges from 100 ppb – 50'000 ppb
Min. detectable concentration*	0.4 ppb
Noise at zero point (1σ)*	<0.2 ppb
Lag time	<3 sec
Rise time (0–90%)	<1 sec
Temperature range	0 - 40 °C
Humidity tolerance	5 - 95% rel. h (non-condensing, ambient air and sample gas)
Sample flow rate	1.0 l/min
Dry air flow rate	0.3 l/min
Input pressure	600-1'200 mbar abs.
Dry air use for O ₃ generator	internally generated (no external supply gas required)
Power required	400 VA (incl. membrane pump and ozone scrubber)

Supply voltage	100–240 V / 50–60 Hz
Interface	USB(3x), HDMI, Bluetooth, RS232 (w/o 9pin connector), LAN, WLAN
Dimensions	height: 133 mm (5¼ ") width: 450 mm (19 ") with molding: 495 mm depth: 540 mm (21.2 ")
Weight	23 kg (51 lb)
Delivery includes	nCLD 855 Y analyzer, power cable, FTDI-RS232-USB cable, USB-LAN adapter, HDMI adapter
Standard	nCLD 855 Y · Y - molybdenum converter
Options	<ul style="list-style-type: none"> · V1 - single calibration valve · V2 - two calibration valves for pressurized calibration (zero & span / 2-3 bar) · h - hot tubing · r - electro-mechanical pressure regulation · USB-RS232 9pin connector · 0 - 10 V · 4 - 20 mA into 500Ω max.
Analog output (External Box)	

© ECO PHYSICS AG, Switzerland 2019 - 1/5

FLOW DIAGRAM

* depending on filter setting
Connectivity properties are country-specific
ECO PHYSICS reserves the right to change these specifications without notice.

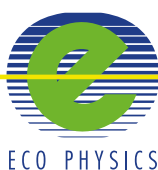
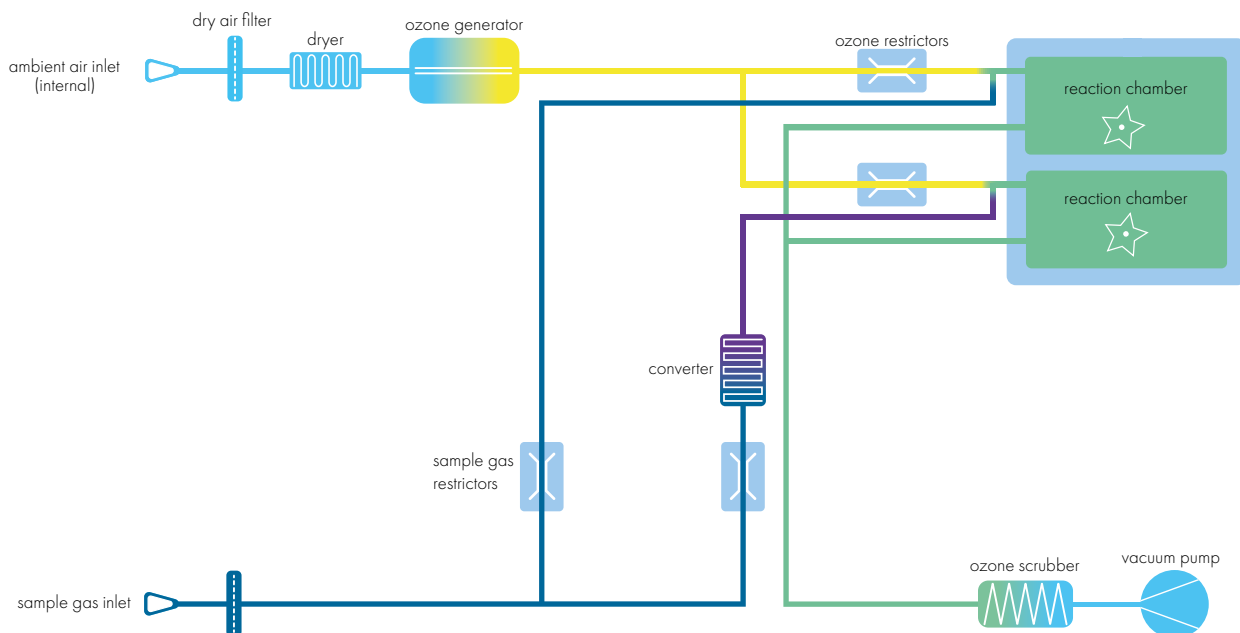

ECO PHYSICS INC. · 3915 Research Park Drive, Suite A-3 · ANN ARBOR, MI 48108-2200 · USA · Phone: (734) 998-1600

sales@ecophysics-us.com · www.ecophysics-us.com